

RAJ STARCH AND LIQUID GLUCOSE PLANT



Raj History and Background



*M*ore than one decade of relentless, customer oriented strong approach and the continuous desire to achieve highest quality standards have enabled. Raj Process Equipments and Systems Pvt. Ltd. to attain and sustain exponential growth in all its major business lines.

Raj Process Equipments and systems Pvt. Ltd. is an ISO 14001:2004, IBR, BS OHSAS 18001:2007 company which was founded by Engineers as a private sector enterprise with businesses in chemical, pharmaceutical and food process equipments and turnkey solutions. Starting as a process equipments company, Raj Process Equipments with continuous quest and urge to provide total Turnkey solutions, pursued a strategy of becoming a solution provider, as an equipment or turnkey, to Chemical, Pharmaceutical, Bio-chemical, Ceramic, Minerals, Fertilizer industries. Through continuous evaluations, evolution and up gradation of products, quality systems and infrastructure we are setting foot in unventured sectors like Refineries, Gas, Critical High Temperature & Pressure Vessels and Reactors, Material handling, Bio-Diesel and Atomic Energy. Presently Raj Group's activities span design, manufacture and erection commissioning of Distillery plants molasses and Grain Based, Detergent Powder Plant, Starch and Glucose Plant, Micro Crystalline Cellulose Powder Plant, Guar gum Plant, Zero Liquid discharge plant, Nutraceutical Powder Plant, milk Powder Plant, Herbal Extraction Plant, Thermal Desorption Plant, Food Processing plants and equipments, Dryers, Evaporators, Mixers, Allied Products, Boilers, Electrical and Automation etc. as per customer design or In-house design.

Raj Process Equipment has an international presence with exports to USA, Italy, Malaysia, Cuba, Israel, Indonesia, Qatar, Bahrain, Oman, Finland Nigeria, Uganda, Bhutan, China, Bangladesh, Sri Lanka, Iraq, Ukraine and with an aggressive marketing approach to spread offices across the globe. The company's future export business will be supported by wide marketing and distribution network with a reputation of strong customer support.

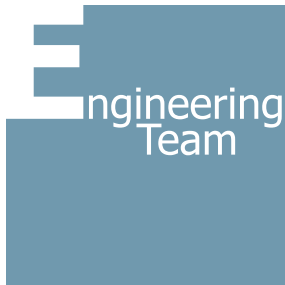

As far as RAJ's technology and engineering practices are concerned, the emphasis is given to nurture research and development and also encourage new ideas. The emphasis has also been on providing the tailor made solutions to meet different conditions and requirements of the clients. The engineering team ensures that all plants, machineries and associated equipments are designed, fabricated and erected based on the following international standards.

ASME / API / TEMA / DIN / JIS for mechanical designs.

ISA / IEEE Codes for electrical and instrumentation.

Civil & structure design conforming to local country code & good engineering practices.

Architecture and aesthetics in line with international developments as per international practices and finishes. The plant layout and overall configuration is conceptualized keeping in mind future expansion, ease of operation, accessibility from road, aesthetics & stringent safety norms.



Project and Construction Team

The focus has also been given to the workmanship and quality control at manufacturing workshop.

All the equipment manufactured by RAJ and its vendors confirm to the international designs, fabrication codes and procedures. The project team utilizes Primavera software for better scheduling and effective project management.

A vast experienced and dedicated team consisting of mechanical engineers, electrical engineers and are always on the move on 24 X 7 days basis to ensure all the projects are implemented in time and with quality.

Commissioning & After Sales Team

RAJ has also been solving the existing plant's technical problems and there are number of examples where RAJ has moved in and solved the difficult problems of quality and efficiency. RAJ is thus able to provide prompt and efficient services to its clients. Clients feel assured that RAJ engineers will be around them to help them in the moment of crisis and this is the simple secret of RAJ getting repeat orders in India and in overseas markets.



Raj Starch and Liquid Glucose Plant

STARCH INTRODUCTION

Starch is a polymer of glucose found in most plants. Starch is produced from various raw materials like maize, Cassava/tapioca roots, potatoes, wheat, rice etc. The technology or the manufacturing process of starch differs according to the raw material used. Customized or specially developed starch is popularly known as Modified starch. This is superior quality starch applicable for varied industrial usages.

To facilitate these aspects of starch extraction or processing, we design & develop starch processing plants that meet varied requirements in starch & its derivative manufacturing units. Our advanced fabrication facilities, team of industry professionals & technical know-how enable us to meet client's specific requirement by developing custom design machinery. We also excel in establishing of complete plants for starch extraction & execute turnkey projects.

USAGE OF STARCH

As a pure & renewable natural polymer starch caters to multiple usages. Its significance as a polysaccharide leads to production of Dextrose, glucose, fructose, maltose & sorbitol. Furthermore, starch is also an important ingredient for the sugar industry, which was otherwise relying upon sugar cane and beet sugar. Some of most common industries where starch is used are Ceramics, Textiles, Printing Industry, Bio-Plastics

Body powder, Oil exploration, Bio-ethanol, Hydrogen Production, Papermaking, Adhesives etc.

MANUFACTURING PROCESS OF STARCH FROM MAIZE

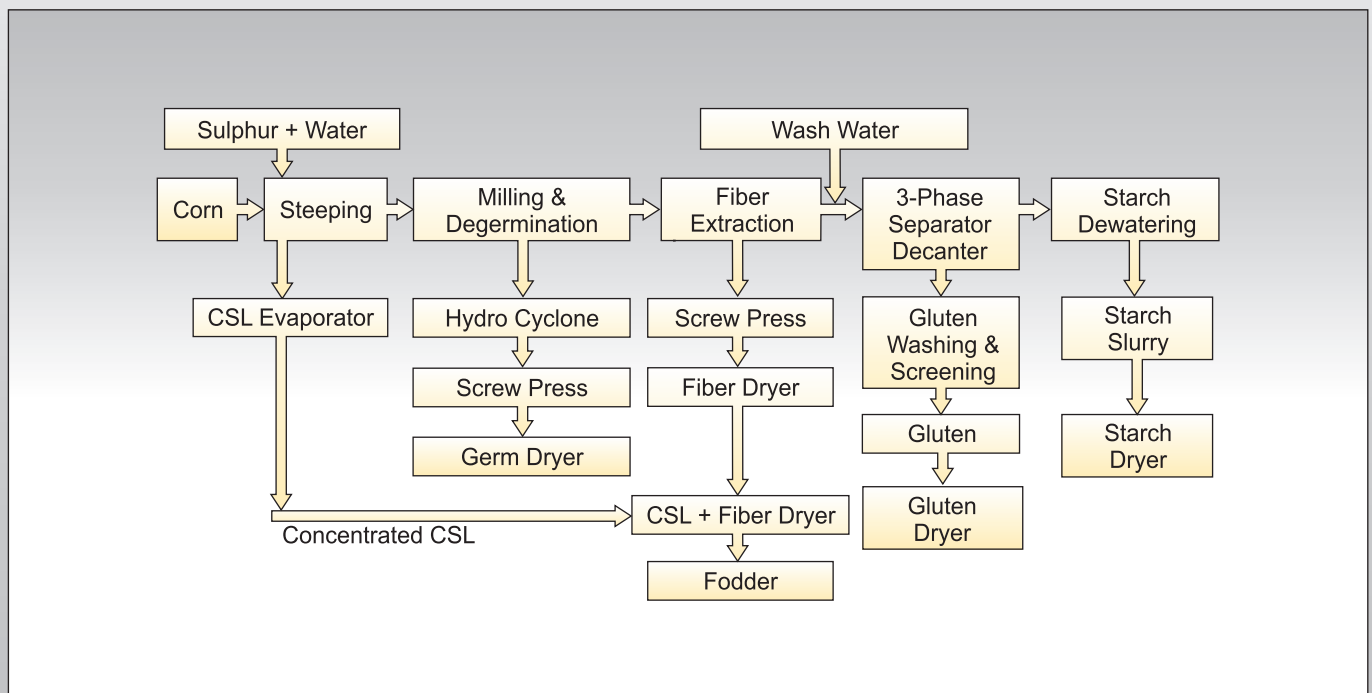

MANUFACTURING PROCESS OF STARCH AND LIQUID GLUCOSE

Manufacturing process of starch and liquid glucose consists of following major steps

MAIZE PRECLEANING, RECEIVING AND WEIGHING

Major operation involved in this process are De-stoning, Dust Removal, Primary Cleaning.

MAIZE STEEPING

The Maize are soften with the help of Sulphur water for primary grinding of the maize.

SULPHUR WATER GENERATION

Sulphur water required for steeping is generated in this process either by burning sulphur or by mixing sodium sulphate in water and then passed through absorption column.

Steeping Vats



CORN STEEPED LIQUOR (C.S.L.) SECTION

Steeped water generated in steeping process is continuously recycled and it consists of Protein, Sugars and Lactic Acids. This water is concentrated by using multiple effect evaporators.

COARSE GRINDING AND DEGERMINATION

Key Equipments used for this operation are listed below

- Screening
- De-Germing Mills
- Hydro-Cyclones
- Screw Press for Germ Dewatering
- Steam Tube Bundle Dryer for Germ Drying

Hydro Cyclone

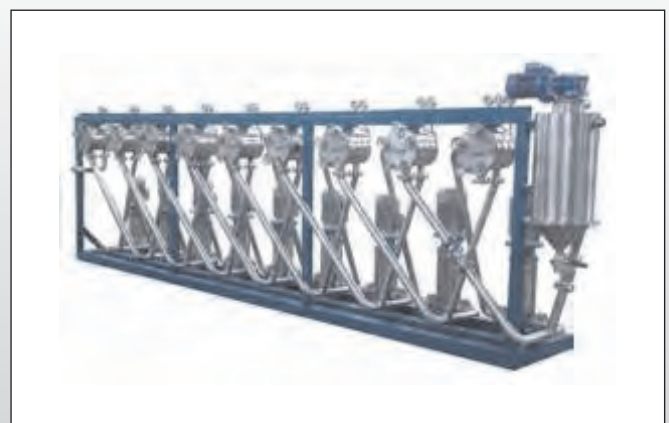

Screw Press

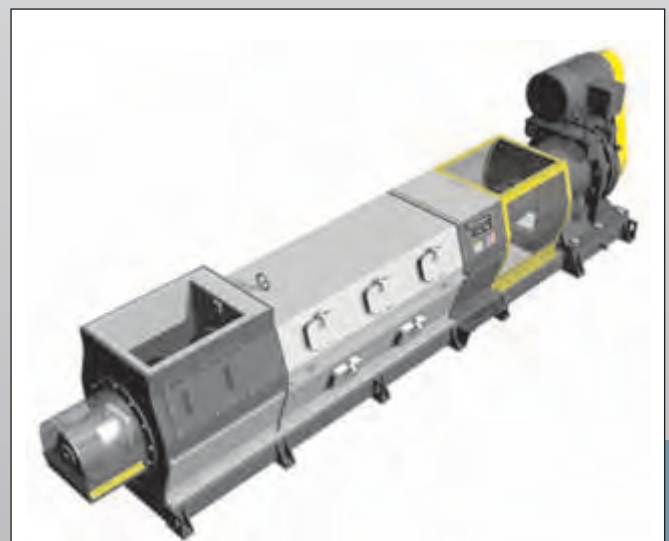

Raj Starch and Liquid Glucose Plant

FINE MILLING AND FIBRE WASHING

Key Equipments used in this process are listed below

- Screening for separation of Starch and Gluten
- Fine Mills
- Screw Press for Fiber Dewatering
- Steam Tube Bundle Dryer for Fiber Drying

STARCH SEPARATION AND STARCH REFINING

Key Equipments used in this process are listed below

- De-Gritting Cyclones to remove small impurities
- Nozzle Separators
- Multistage Counter Washing Hydro Cyclones

GLUTEN DEWATERING AND DRYING

Key Equipments used in this process are listed below

- Decanter for Gluten Dewatering
- Spin Flash Dryer/Tube Bundle Dryer for Gluten Drying
- Pneumatic Conveying

STARCH DEWATERING AND DRYING

Key Equipments used in this process are listed below

- Centrifuge for Starch Dewatering
- Pneumatic Flash Dryer
- Pneumatic Conveyor

LIQUID GLUCOSE PLANT

Liquid glucose is also known as Glucose or Corn Syrup is aqueous solution of several compounds namely Dextrose, Dextrins and Maltose. Corn syrup is used in foods to soften texture, add volume, prevent crystallization of sugar, and enhance flavor.

Liquid Glucose is manufactured from starch by incomplete acidic or enzymatic hydrolysis of starch followed by refining and evaporation.

The starch slurry is pumped to the holding tube via Jet cooker, where the slurry will be treated with higher

Grinding Mills



Nozzle Separator



Steam Tube Bundle Dryer



temperature and then passed to flash vessel for cooling then it is fed to liquefaction tank which is two stage process where liquefaction of starch slurry takes place & the partial conversion of starch into glucose molecules takes place. The converted product is then passed to saccharification tanks via inter stage cooler and further fed to ion exchange column to remove the impurities.

After ion exchange treatment the solution is passed through an evaporator to increase the solid contents. This evaporation will remove large amount of water from the liquid. The glucose is passed over UV unit & send to storage tank.

Key process involved in liquid glucose manufacturing are listed below

- Slurry Preparation,
- Cooking section,
- Saccharification,
- Filtration,
- Ion Exchanging,
- Multi Effect Evaporation.

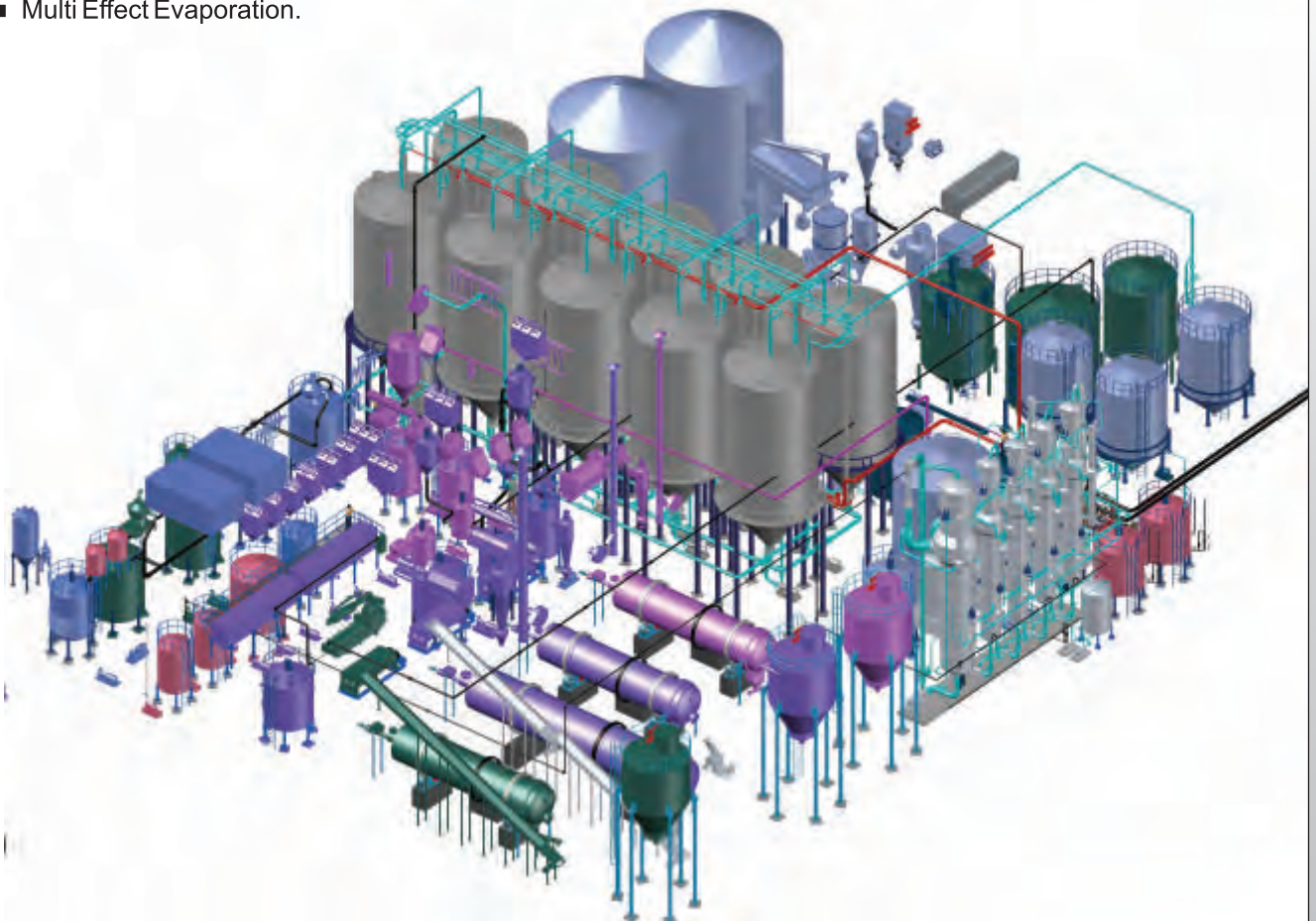



Corporate and state of the art engineering office

RAJ is a process-engineering house serving the dryer, Evaporator, distillery and bio-fuels industry with its strong team of professional engineers from various disciplines. The modern corporate office

located in Akurdi Pune, India with networking facilities which is design hub for its domestic and international projects.

Fabrication and quality testing facility

RAJ today has a manufacturing base in PUNE India of 4 workshops capable of manufacturing around 20 large sized distillery and Ethanol projects per year. Many International third party inspection and quality conformance agency certifies the engineering & fabrication drawings, actual fabrication and shop floor activities thereby adding value to our quality manufacturing set-up.

Manufacturing Facilities

We have four manufacturing units, of which, one is for exports. We have our manufacturing facility in Khed SEZ, near Pune on Pune Nasik National Highway. Second unit is in Bhosari Industrial Area nearby Pune, which is dedicated to R&D, that ensures products with unmatched quality, third one is in Chakan area, and Fourth one is in Shirval, near Pune.

Chakan Unit

Chakan Unit

(Stainless Steel and Special Equipments)

Our Chakan unit has separate divisions for manufacturing different products. The uniqueness of the plant is it has all the fabrication processes in house which makes it to manufacture a product much faster than competitors. The area covered by Chakan Unit is 20000 Square Meters.

Bhosari Unit

(R&D Unit & ElectricalAutomation)

This is available with the land of 800 Square Meters area totally covered.

These manufacturing units are laced with the Hi- tech pilot facilities and testing equipments. The facilities are backed by the team of experienced engineers who work efficiently to achieve complete customer satisfaction. The design department of our company is equipped with

Bhosari Unit



software's that enable us to design the product on computer and develop it according to the industry specific need of the customer. Bhosari Unit is dedicated for R&D to ensure products with unmatched quality.

Khed Unit / Pabal Unit

(Export house)

This unit is located in First Multiproduct Special Economic Zone, Pune developed by Kalyani Group. Khed Unit is dedicated to exports and SEZ orders only. We have complete manufacturing set up as per International Norms. This is available with the land of 20000 Square Meters area.

Shirval Unit

(Carbon Steel and Heavy Fabrication)

Due to increasing demand for our products we have expanded our manufacturing facility at Shirval in Satara District. The manufacturing facility started functioning from July, 2013. This new facility is in 14 acres.



M Marketing Network

Raj Process Offices and Marketing Network:

Raj has a strong domestic as well as International Marketing network.

Marketing offices in Delhi, Chennai, Ahmadabad, and Hyderabad in INDIA.

And Malaysia, Indonesia, Ukraine, Russia, Israel, Dubai, Nigeria, Kenya, Ethiopia etc Internationally.

Khed Unit (Pabal)



Shirval Unit (Khandala)

Certifications

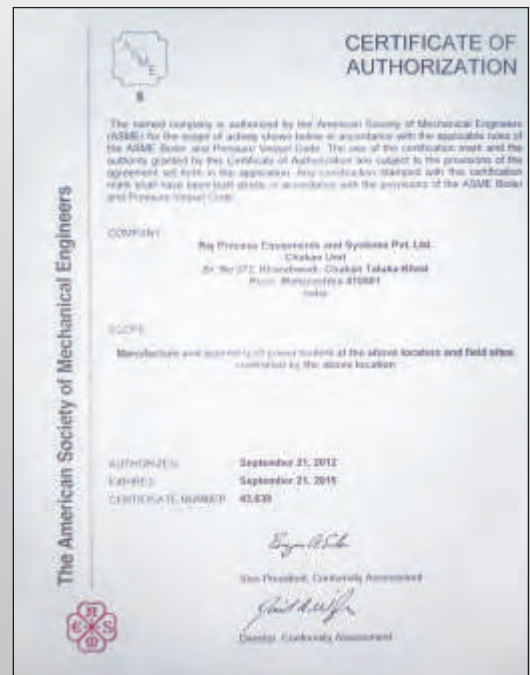

Our Esteemed Customer

ZAR INDUSTRIAL & RESEARCH GROUP, IRAN



EVEREST STARCH, INDIA



HONEST DERIVATIVES Pvt.Ltd.



VEDANT STARCH PVT. LTD.

Vedant Starch Pvt. Ltd.

SPAC STARCH PVT. LTD., INDIA



Yashwant Sah. Glucose Karkhana Ltd, India.



SHRI TRADCO DESSAN PVT. LTD., INDIA

Product/ By-products from Starch Plant

Maize Starch



Maize Fiber



Maize Gluten



Maize Germ



Head Office

- Jai Ganesh Vision, 'B' Wing, 3rd Floor,
Jai Ganesh Fame Building, Akurdi, Pune - 411035, India
Tel: +91-20-40710010
Telefax: +91-20-40710009
Email: sales@rajprocessequipment.com
Website: www.rajprocessequipment.com

Regional Offices

- Hyderabad
Cell.- +91-9550151122.
- C-24 Barcelona Business Hub,
Odhav Circle, S P Ring Road, Odhav, Ahmedabad- 382 415
Cell. - +91-7600022352
- Unit No. FF-47, 1st Floor, Omaxe Square,
Jasola District Centre, Behind Jasola Apolo Hospital,
New Delhi - 110 044; Tel. +91-11-40503519
- Second Floor, No: 6/9, HariKrishna colony,
Nandambakkam, Chennai-600 089.
Cell:+91-8220058290

Marketing Representative- International

- Bio-Tropic Industries Sdn. Bhd.
19 -1 A , 1st Floor , Block 6 , Jalan Pahat H / 15 H,
Seksyen 15 ,40200 Shah Alam,
Selangor Darul Ehsan , Malaysia
Tel.- +6 03 5523 2219 , Fax - +6 03 5523 9995
Contact Person - Mr. Ganesan , Cell.- +60355239995
E-mail - sales@bio-tropic.com.ganesan@bio-tropic.com
- PT. Keiso Process & Enviro Industries
Jl-Tarum Barat II Blok Kav, Pl.No.30, Cikarang Baru,
Cikarang, Bekasi - Indonesia
Tel. - +62-21-29083225, +62-21-92755156
Contact Person - Mr. Irawan
- Mykhaylo Siyatskyy
Apt 3, Tsupov Block Bld 18, Lugansk, Ukraine-91002
Tel. - +380501435566
Email - michaelSIYATSKYY@gmail.com
- OOO Castola Moscow,
Suchevskaya Street 19, Block 4
Tel - 8 (495) 787-95-32, 787-62-27, Cell. - 8 (903) 960-10-15
Contact Person - Mr. Nikolay Kurilovich
Email - cast2305@mail.ru
- FC GIDA VE MAKINA VE DIS TICARET ANONİM SİRKETİ
Istanbul dünya ticaret merkezi,
B2 Blok, kat 6, No 227, Istanbul, Turkey
Tel. 0090 212 560 4625
- Simra Intl. Fze.
PO Box 46798, Dubai - UAE,
Contact Person - Mr. Saleem Shaikh
Cell. - +971 50 5586727
Email - simra_intl_fze@yahoo.com

Manufacturing

- Unit-I, Plot No. 166 & 167, Sector No. 7,
PCNTDA Bhosari, Pune - 411 026 (India)
Tel. - +91-20-27119973, 27124145
- Unit-II, Sr. No. 373, Village Kharabwadi,
Chakan, Tal. Khed, Dist. Pune (India)
Tel. - +91-2135-252251, 255654
- Unit-III, Plot No. I-14, SEZ,
Village - Nimgaon, Tal. - Khed, Dist Pune - 410505 (India)
- Unit - IV Gat No. 530, A/p Ahire,
Tal - Khandala, Dist - Satara - 412802
Tel. - 020-40710010



RAJ PROCESS EQUIPMENTS AND SYSTEMS PVT. LTD.

